

Home Automation System By Source Of Renewable Energy Using Zigbee Method

Pramod Kumar

Asst. Professor, Department of Electrical Engineering, UIET, Baba Saheb Bhimrao Ambedkar University, Lucknow

Abstract: The elevation in earlier years in electronics and communication, computer science and information technology domain has resulted, that we can generate the energy by using renewable energy sources. For management of home equipments we can use this energy. However, the existing systems do not allow a user to get a feasibility to actively mitigate the power consumption of home equipments. In the earlier days, the electric home equipments can be controlled and monitored with the help of homespun power lines by using power line communication technology. But, now days a Zig bee technology is used for the electric home equipments for controlling and monitoring for more probable than before. This paper describes the methodology of renewable energy based home automation in which two things are consider one is energy consumption and another is energy generation. In this, ZigBee is used for monitoring energy consumption of home equipments and Power Line Communication (PLC) is used to monitoring energy generation. Then home server collects the energy consumption data and energy generation data and analyzes them for energy approximation and control the home energy utilization schedule to slump the energy cost. Then energy data of home servers evaluates them, and generates useful statistical examination information aggregated by the remote energy management server. The system gives more efficient energy saving and result in home energy cost reduction.

Keywords: Renewable Energy, Zig Bee, Power line communication, Renewable energy based home automation.

I. INTRODUCTION

Automation is today's fact, where more things are being completed every day automatically, usually the basic tasks of turning on or off any devices and across, either remotely or in close proximity. The control of the appliances when completely taken over by the machines, the process of monitoring and reporting becomes more eventful. We are more and more relinquishing the power for simple but routine tasks while we need to maintain as much control as we can over the automated processes. Automation is down the human judgment to the lowest degree possible but does not completely eliminate it. Depending on the location of its usage, automation differs in its name as industrial automation, home automation etc. With the development of low cost electronic Components, the industrial application is migrated to home automation.

Renewable energy is generally defined as energy that comes from resources which are naturally replenished on a human timescale such as sunlight, wind, rain, tides, waves and geothermal heat. Renewable energy replaces conventional fuels in four distinct areas: electricity generation, hot water / space heating, motor fuels, and rural (off-grid) energy services. This project is fully deploying the renewable energy resources.

The energy consumption in home areas has greater as more home equipments are used. So that energy disaster has required consequence reduction in allover area. For solving this home energy adversity, we consider energy saving and another one is energy renewable sources. At the same time we also have to save the home energy cost, for this, two things must be consider and these are energy consumption and energy generation. So that we can use home automation with the help of renewable energy sources that we implement a new system, called it as renewable energy based home automation.

II. PROPOSED SYSTEM OF RENEWABLE ENERGY BASED HOME AUTOMATION USING ZIGBEE

A. SYSTEM USED

The Fig.1 shown above is the proposed system of Renewable energy based home automation. It is illustration of how we have implemented the project and the various parts involved in it. In this system, it has two main sections i.e. energy consumption and energy generation.

Energy consumption: This section contains home equipments and lights which are monitored with the help of energy measurement and communication unit. Energy measurement and communication unit is installed in each light and outlets for measurement of energy and power consumption of home equipments and lights. Energy measurement and communication unit sends the measured value after some specific time spam towards the home server with the help of Zig Bee.

Then home server incorporates the energy and power data from lights and from outlets through ZigBee access point (AP). Then ZigBee access point analyzes the incorporate data and makes the energy and power consumption profile of home equipments and lights. Users can graze the energy and power information and figure out the energy consumption of home equipments and lights, with the help of home server.

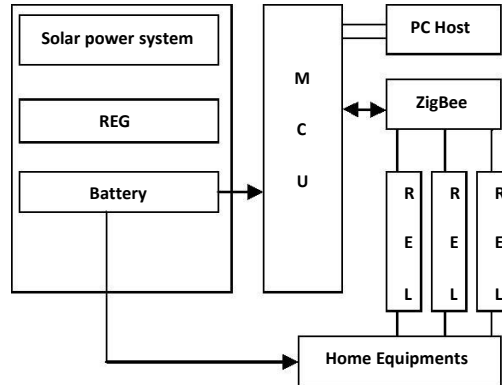

Fig. 1: Proposed System of Renewable Energy Based Home Automation Using Zigbee

Energy Generation: This section contains solar power system. The solar power system contains PLC modems, a solar panel and an REG. The renewable energy gateway (REG) is used for monitoring the energy generated from solar power system. Each solar panel is has a PLC modem for making the communication with REG. The PLC modem monitors the solar panel and send the monitored result towards the REG. The solar power system consist the solar inverter. Solar inverter converts this DC power into AC power. The solar inverter is attached to the REG through serial communication. The REG collects the data of solar panel and inverter and send this collected data towards the home server. From the collected data home server makes the energy and power profiles.

B. Energy Management and Communication Unit

Fig.2 shows the block diagram of energy measurement and communication unit which consist of two main blocks one is measurement block and another is communication block.

Measurement Block: Measurement block uses metering IC for measuring the power, energy of home equipments. The metering IC compute the voltage and current in sample period, it multiplies them and integrates them continuously. By measuring the voltage and current it measures the power and energy. The measurement block stores only collected energy data at a memory.

Measurement block also contain a power control which is used to supplies or blocks the electricity to attached home equipments.

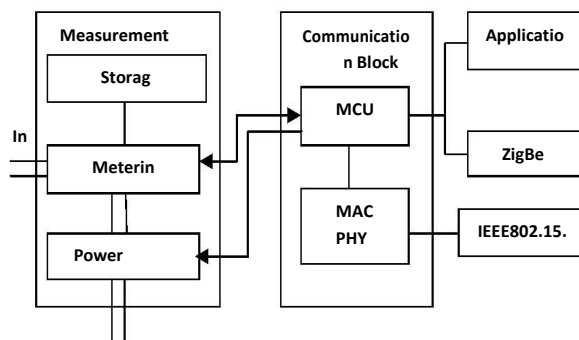

Fig.2: Block Diagram of Energy Management and Communication Unit

Communication Block: This block contains MCU. MCU is used to control status of power control block in response to the response from the home server. Data transfer between the EMCU and home server is done with the help of communication block. Communication block use the communication method by adopting ZigBee and IEEE 802.15.4 wireless personal network.

Zigbee is based on an IEEE 802.15 standard. Though low powered, ZigBee devices can transmit data over long

distances by passing data through low powered, ZigBee devices can transmit data over long distances through intermediate devices to reach more distant ones, creating a mesh network; i.e., a network with no centralized control or high power transmitter/receiver able to reach all of the networked devices. The decentralized nature of such wireless ad hoc networks makes them suitable for such applications where a central node can't be relied upon. In any application when there is requirement of low data rate, long battery life and secured networking then it uses ZigBee.

ZigBee networks are secured by 128 bit symmetric encryption keys. In home automation applications, transmission distances range from 10 to 100 meters line- of-sight depending on power output and environmental characteristics. Fig.3.shows block diagram of data transfer message format in a ZigBee payload. The wireless nature of ZigBee helps to reduce the unsolicited installation difficulty with the existing home automation systems identified earlier. The ZigBee standard theoretically provides 250kbps data rate, and as 40kbps can meet the requirements of most control systems, it is adequate for controlling most home automation equipments.

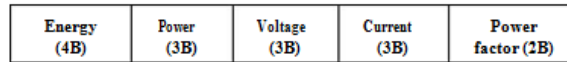

Fig.3: Block Diagram of Data Transfer Message Format in Zigbee Payload

C.SERVER USED

The Home Server connects user interface to hardware interface. It has application programming, which communicate with user and microcontroller via ZigBee. Home server sends command to microcontroller through ZigBee transceiver. Microcontroller receive signal and run accordingly to carry out specific operations. Home server modifies the home equipments schedule so that the energy cost is reduces which is based on approximate energy generation. The home server has some functional blocks one of them is EMCU which is installed in outlets and lights through a ZigBee access point. The home server used the node control block for monitoring and controlling the EMCU block. The block is energy generation manager (EGM) it analyzes the renewable energy generation. The next Block is energy consumption manager aggregated data which is stored in information database. The home server also consists of user interface block which shows the energy generation and energy consumption information over time.

D. PLC Modem

It is the part of energy generation block. In energy generation block, REG is used which is connected to PLC modem, solar inverter.Fig.4 shows the block diagram of PLC modem. The sensing agent is used to measure the voltage and current of solar panel. The PLC modem sends this sense data towards REG.

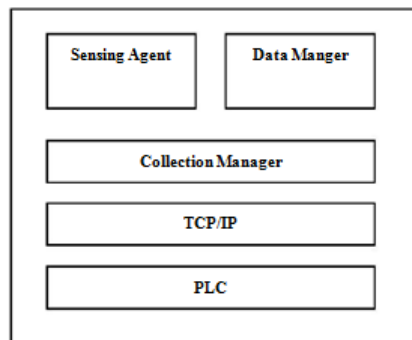

Fig.4: Block Diagram of PLC Modem

Connection manager control the connection between REG and PLC. TCP/IP protocol is used to communicate with PLC modems over PLC. As an identifier they have their own IP address.

E. Renewable Energy Gateway

Renewable Energy Gateway It consists of three communication interfaces, PLC, Ethernet and RS 485 for each solar panel, for the home server and for the inverters respectively. Fig.5 shows the block diagram of REG. It has main block i.e. data aggregator. The PLC modem and inverter receives the data request message from data aggregator and sends the status data to the data aggregator. Solar inverter is connected through the RS 485.The data sender sends the aggregated data to the home server periodically.

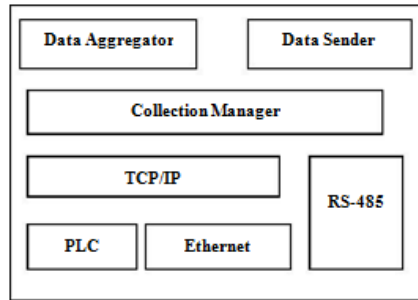

Fig.5 Block diagram of REG

III. CONCLUSION

As we used renewable energy source to save the energy cost in this system, two things are important and i.e. energy consumption and energy generation. Energy consumption is based on ZigBee. In the energy consumption, it measures the energy usage of home equipments based on ZigBee and home server receives this collected data from ZigBee. Energy generation is based on PLC. Energy generation also have renewable energy gateway. PLC is used for monitoring the solar panel. The REG collects the status of solar panel and sends this collected data to the home server. Renewable energy gateway (REG) is considered for both the things i.e. Zig Bee based energy consumption and PLC based energy generation. Hence by taking both consumption and generation, the home server optimizes home energy use.

REFERENCES

- [1]S. Cuk and R. D. Middlebrook, "A new optimum topology switching+33 DC-to-DC converter," in Conference Rec. 1977 IEEE Power electronics Specialist Confe.,pp. 160-179.
- [2]S. Cuk and R. D. Middlebrook, "Coupled-inductor a. nd other extensions of a new optimum topology switching DC-to-DC converter", in Conf.Rec.1977 IEEE Industry Application Society Annual Meeting pp.1110- 1126.
- [3]R. Massey and E. Snyder, "High voltage single ended DC-DC converter," in conf.Rec.1977 IEEE Power electronics Specialist conf.pp.156-159.
- [4]S. Cuk, "A new zero-ripple switching DC-to-DC converter and integrated magnetics," IEEE Transformer on magnetics,vol.19,no.2,pp.57-75, March1983.
- [5]F. S. Dos Reis, J. Sebastian, and J. Uceda, "Characterization of conducted noise generation for Sepic, Cuk and Boost converters working as power factor preregulators,"in conf. Rec. 1993 IEEE ,pp.965- 970.
- [6]L. Huber and M. M. Jovanovic, "A design approach for server power supplies for networking,"inconf.Rec.2000 IEEE Applied Power electronics conf.pp.1163-1169.
- [7]B. Axelrod, Y. Berkovich, and A. Ioinovici, "Transformerless DCDC converters with a very high DC line-to-load voltage ratio," in 2003 IEEE International Symposium on circuit and system, vol.3,pp.435-438.
- [8]H. Nomura, K. Fujiwara, and M. Yoshida, "A new DC-DC converter circuit with larger step-up/down ratio" in conf. Rec.2006 IEEE Power electronics specialist conf.pp.1-7.
- [9]R. W. Erickson and D. Makismovic, "Fundamentals ofpower electronics".2nded,Spinger Science.USA,2001.ch.6.
- [10]D. S. L. Simonetti, J. Sebastian, "The discontinuous conduction mode Sepic and Cuk